



**NEW
3D AOI**



Innovative
Inspection of PCB
Top and Bottom
Sides



iS6059 Double-Sided Inspection

Simultaneous optical quality control from above and below

3D AOI

Unmatched 3D AOI for Flawless Inspection on Both Sides

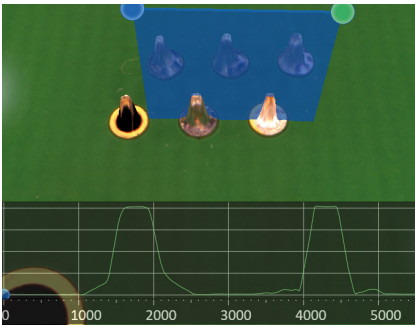

Reliable 3D inspection of THT solder joints



Insufficient wetting (front) and missing pin (back)

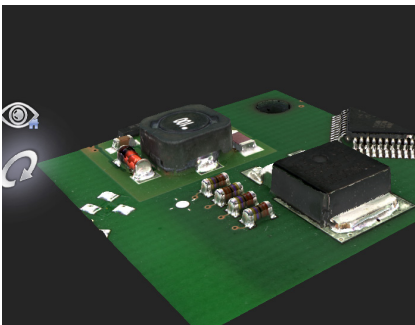

Realistic inspection images with 360View

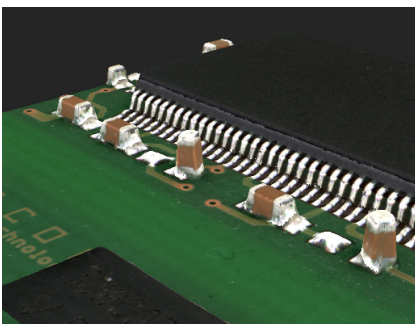

Reliable detection of defects such as tombstoning

Powerful 3D sensor technology for quality control from above and below

Shadow-free results by using eight angled cameras respectively

Versatile handling of many different inspection object types

Comprehensive networking options including IPC Hermes 9852 and IPC CFX

Reduction of cycle times thanks to inspection from both sides

Competent service worldwide – online, by phone, and on-site

The iS6059 Double-Sided Inspection is an automatic optical inspection system (3D AOI) for inline use in the electronics manufacturing industry. It can inspect assemblies from above and below without requiring objects to be flipped.

A special feature of the iS6059 Double-Sided Inspection are two state-of-the-art sensor modules (each equipped with 9 cameras and a structured-light projector), which capture images and 3D height information on separate traversing units.

The simultaneous double-sided inspection fulfills the high demands that Viscom places on its systems in terms of throughput, durability, analysis functions and connectivity.

Important key user segments are manufacturers of products from the electric vehicle, charging infrastructure, and renewable energy sectors, that are still using through-hole technology (THT). Another area of use is various applications with double-sided SMD assembly.



Technical Specifications iS6059 Double-Sided Inspection

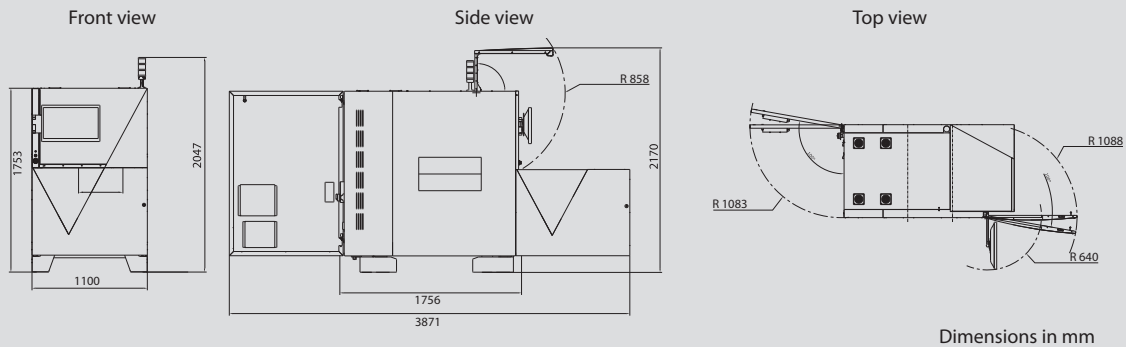

iS6059 Double-Sided Inspection

Inspection scope		Selective and wave soldering, standard solder joints according to IPC, open surfaces, character recognition, solder paste, mold, press fit
Camera technology		2 x XMu-II
	3D sensor technology	
	Z-resolution	0.5 μm
	Z-range	Up to 30 mm (1.2")
	Angled view cameras	
	Number of megapixel cameras	8
	Orthogonal camera	
Inspection speed	Resolution	13 μm
	Field of view	50 mm x 50 mm (2" x 2")
Inspection speed		Up to 100 cm^2/s (both sides combined)
Software	User interface	Viscom vVision
	Statistical process control	Viscom vSPC/SPC, open interface (optional)
	Verification station	Viscom vVerify
	Remote diagnosis	Viscom SRC (optional)
	Programming station	Viscom PST34 (optional)
System computer	Operating system	Windows®
	Processor	Intel®Core™i9
PCB handling	PCB dimensions	508 mm x 560 mm (20" x 22")
	Transport height	850 - 950 mm \pm 20 mm (34" - 37" \pm 0.8")
	Width adjustment	Automatic
	Transport concept	Single-track transport system
	PCB clamping	Pneumatic
	Upper transport clearance	50 mm (2")
	Lower transport clearance	50 mm (2")
Other system data	Positioning unit	Synchronous linear motor
	Interfaces	SMEMA, Hermes, third-party providers
	Power requirements	400 V, 50 Hz, 3P/N/PE +/- 10%; 4 - 6 bar working pressure
	System dimensions	1100 mm x 1756 mm x 1753 mm (W x D x H)
	Weight	Approx. 1250 kg (2756 lbs)

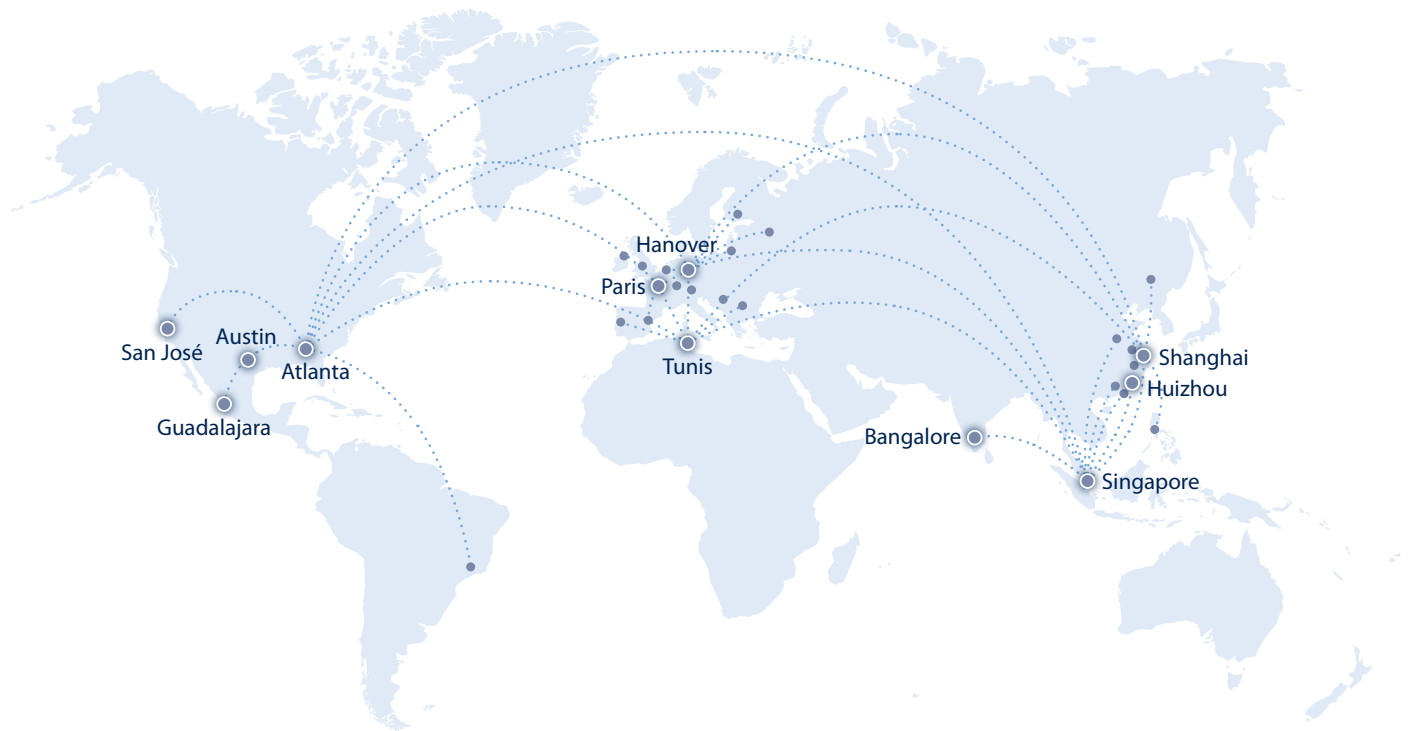

Headquarters:

Viscom AG
Carl-Buderus-Str. 9–15
30455 Hanover
Germany
Phone: +49 511 94996-0
Email: info@viscom.de

Europe

Viscom France S.A.R.L.
6, rue Saint Simon
Zone du Vert Galant
95310 Saint-Ouen l’Aumône
France
Phone: +33 134 641616
Email: info@viscom.fr

Africa

Viscom Tunisie S.A.R.L.
Rahma Building; App B5,
Block B, 2nd floor
Lac Houran Street – Berges
du Lac
1053 Tunis, Tunisia
Phone: +216 71960584
Email: info@viscom.fr

Americas

Viscom Inc.
1775 Breckinridge Parkway
Suite 500, 30096 Duluth,
Atlanta, GA, USA
Phone: +1 678 966-9835
Email: info@viscomusa.com

Viscom Inc.
898 B Faulstich Court
San José, CA 95112, USA
Phone: +1 818 4160514
Email: info@viscomusa.com

Viscom Inc.
9600 Great Hills Trail Suite
150 W, Unit# 144
Austin, TX 78759, USA
Phone: +1 737 280-5759
Email: info@viscomusa.com

Viscom Inc.
Av. Vallarta 6503
Concentro Local F-27
Zapopan (Guadalajara)
JAL. C.P. 45010, Mexico
Phone: +52 333110-1567
Email: info@viscomusa.com

Asia

Viscom Machine Vision Pte. Ltd.
150 Kampong Ampat/
#01-02 KA Centre
368324 Singapore
Singapore
Phone: +65 62859-891
Email: info@viscom.com.sg

Viscom Machine Vision Trading Co. Ltd.
2nd floor, Block D
No. 1010 Kaixuan Road
200052 Shanghai, China
Phone: +86 21 61619368
Email: info@viscom.cn

VICN Automated Inspection Technology (Huizhou) Co. Ltd.
2nd Hechang Road No. 25
Zhongkai High-tech Zone
516006 Huizhou City
Guangdong province, China
Phone: +86 752 2607785
Email: info@viscom.cn

Viscom Machine Vision (India) Pvt. Ltd.
No. 2, Katha, No. 279/283
Hulimangala Village
Jigani Hobli, Anekal Taluk
Bangalore 560105, India
Phone: +91 9481202030
Email: info@viscom.com.sg

www.viscom.com



Viscom also works with an extensive network of local representatives and distributors in Europe, the Americas, Asia and Africa. Please refer to our website for a list of our representatives and distributors.